

KOMATSU

D155AX-8

EU Stage IV Engine

CRAWLER DOZER

PRELIMINARY



D155AX

ENGINE POWER

268 kW / 360 HP @ 1.900 rpm

OPERATING WEIGHT

41.200 kg

BLADE CAPACITY

SIGMADOZER® 9,4 m³
Semi-U Dozer 9,4 m³
U Dozer 11,9 m³

Walk-Around

OUTSTANDING PRODUCTIVITY & FUEL ECONOMY

High productivity & low fuel consumption

- Low consumption EU Stage IV engine
- Unique torque converter with auto lock-up
- Automatic transmission
- Adjustable Eco-gauge and auto idle stop
- Selectable working modes

Optimized work equipment

- Sigmadozer® blade with hydraulic pitch
- Semi-U and U blades
- Variable giant and multishank ripper
- Komatsu-Topcon plug & play provisions (option)



D155AX-8

images may display optional equipment or specifications not available in your area.

First-Class Operator Comfort

- Quiet and comfortable cab
- Fully adjustable air suspension seat
- Superior visibility on blade and ripper
- Less noise and vibrations
- Integrated rear view camera system

State of the art controls

- Hydrostatic steering system
- Gearshift preset function
- Ripper auto-return
- Remote safety lock levers
- Large TFT colour multi monitor

Tough and reliable

- Low-drive undercarriage
- K-Bogie undercarriage system
- Sturdy, rugged design
- Highly reliable electric circuit

KOMTRAX™

- Komatsu Wireless Monitoring System

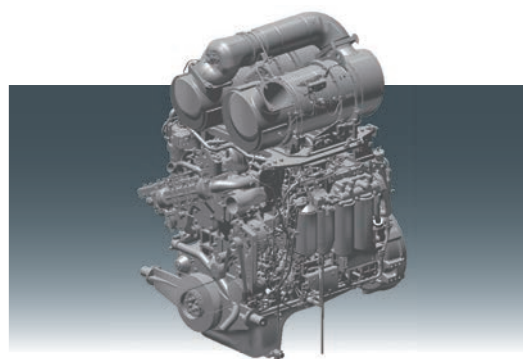

New, low consumption Komatsu SAA6D140E-7 engine for greatly increased productivity.

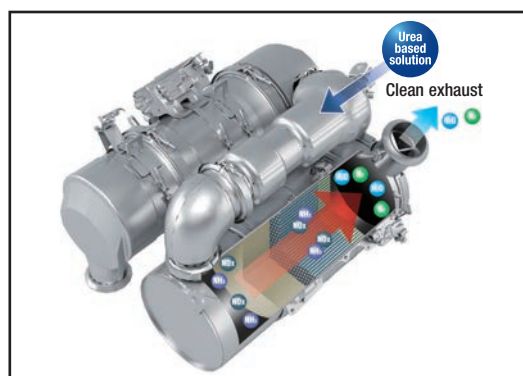

New heavy-duty after treatment system combines the Komatsu Diesel Particulate Filter (KDPF) and Selective Catalytic Reduction (SCR) to fully comply with EU Stage IV emissions.



Fully suspended operator station ensures maximum operator comfort and an excellent view on the blade.



Eco gauge, eco guidance and fuel consumption gauge help to further reduce consumption.



Complimentary maintenance program for customers

ENGINE

Model Komatsu SAA6D140E-7
 Type Common rail direct injection, water-cooled, emissionised, turbocharged, after-cooled diesel
 Engine power
 at rated engine speed 1.900 rpm
 ISO 14396 268 kW / 360 HP
 ISO 9249 (net engine power) 264 kW / 354 HP
 No. of cylinders 6
 Bore x stroke 140 x 165 mm
 Displacement 15,24 ltr
 Engine emissions Fully complies with EU Stage IV exhaust emission regulations

UNDERCARRIAGE

Suspension Oscillating equaliser bar and pivot shaft
 Track roller frame Monocoque, large section, durable construction
 K-Bogie undercarriage Lubricated track rollers are resiliently mounted on the track frame with a bogie suspension system

TORQFLOW TRANSMISSION

Type Komatsu TORQFLOW
 Torque converter 3-element, 1-stage, 1-phase, water-cooled, automatic lock-up
 Transmission Planetary gear, multiple-disc clutch hydraulically actuated, force-lubricated

DIMENSIONS

	D155AX-8 Sigmadozer®
A	4.060 mm
B	2.140 mm
C	3.385 mm
D	1.850 mm
E	3.275 mm
F	8.700 mm
G	3.045 mm
H	1.240 mm
I	950 mm
J	3.390 mm

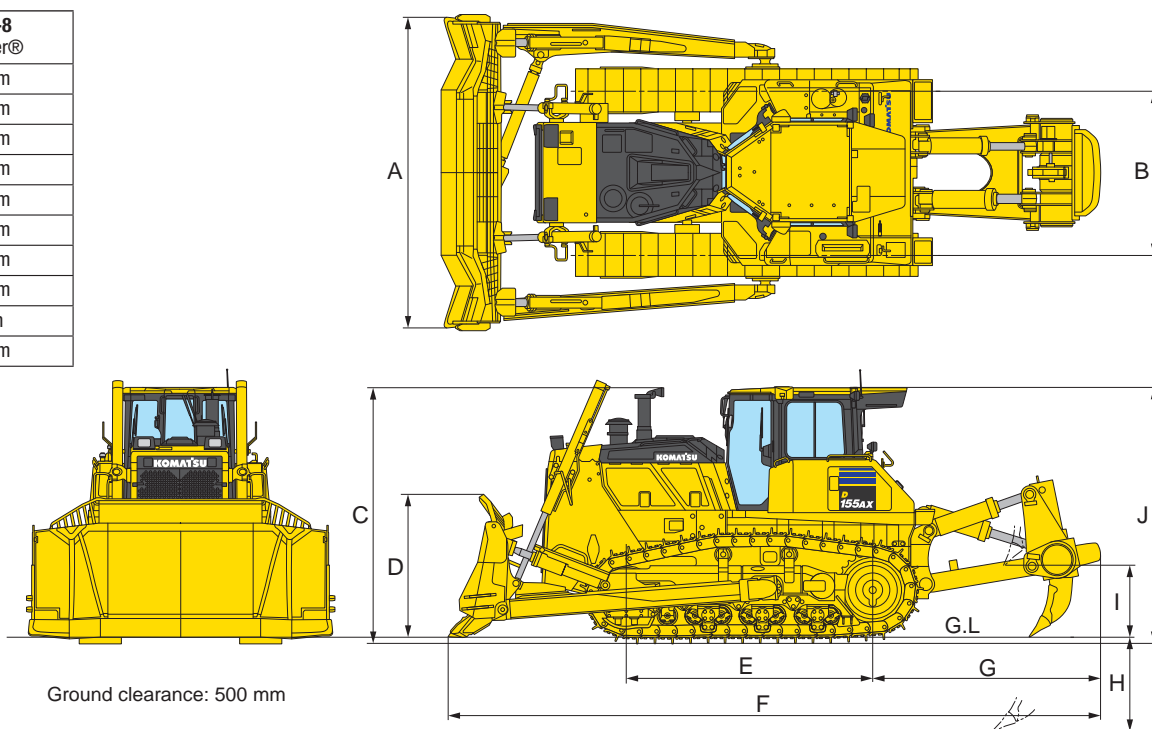

Ground clearance: 500 mm

DOZER EQUIPMENT

	Overall length with blade	Blade capacity	Blade width x height	Max. lift above ground	Max. drop below ground	Max. tilt adjustment	Additional weight
Strengthened Sigmadozer® dual tilt	6.300 mm	9,4 m³	4.060 x 1.880 mm	1.315 mm	680 mm	880 mm	5.900 kg
Strengthened Semi-U blade dual tilt	6.365 mm	9,4 m³	4.130 x 1.790 mm	1.315 mm	600 mm	880 mm	5.900 kg
Strengthened U-Blade dual tilt	6.785 mm	11,9 m³	4.260 x 1.790 mm	1.315 mm	600 mm	920 mm	6.600 kg

Blade capacities are based on the SAE recommended practice J1265.