

Technical sheet

MLT 737-130 PS+

Telehandlers



Capacities	Metric
Max. capacity	3700 kg
Max. lifting height	6.90 m
Max. outreach	3.90 m
Reach at max. height	1 m
Weight and dimensions	
Unladen weight (with forks)	7700 kg
m4 - Ground clearance	0.41 m
l2 - Overall length to carriage (with hitch)	4.97 m
y - Wheelbase	2.81 m
b4 - Overall width of cab	0.95 m
b1 - Overall width	2.39 m
h17 - Overall height	2.38 m
a4 - Crowd angle	12 °
a5 - Dump angle	134 °
Wa1 - External turning radius (over tyres)	3.92 m
Standard tyres	460/70 R24 159A8 A580 - Alliance
Performances	
Lifting	7.60 s / -
Lowering	5.40 s / -
Extension	7.80 s / -
Retraction	5.90 s / -
Crowd	3.80 s
Dump	3 s
Engine	
Brand	Deutz
Environmental norm	Stage IV / Tier 4 Final
Model	TCD 3.6 l
Number of cylinders - Cubic capacity	4 - 3621 cm ³
Power	129 hp / 95 kW
Max. torque	500 Nm at 1600 rpm
Reversible fan	Standard
Cooling system	4 radiators (water + intercooler + hydraulic oil + transmission oil)
Transmission	
Type	Torque Converter with box Powershift Plus
Number of gears (forward/reverse)	6/3
Max. travel speed (may vary according to applicable regulations)	40 km/h
Differential lock	Limited slip differential on front axle
Parking brake	Manual parking brake
Service brake	Hydraulic oil immersed multi-disc braking on front & rear axles
Hydraulics	
Hydraulic pump type	Load sensing pump
Flow sharing distributor	Standard
Hydraulic flow - Pressure	150 l/min - 270 bar
Tank capacities	
Hydraulic oil	135 l
Fuel	120 l
Diesel Exhaust Fluid (AdBlue® type)	10 l
Noise & vibration	
Noise at driving position (LpA) tested following NF EN 12053 norm	73 dB(A)
Environmental noise (LwA)	105 dB(A)
Vibration to whole hand / arm	<2.5 m/s ²
Miscellaneous	
Safety	Tractor homologation EN 15000 Norm Cab ROPS - FOPS Level 2

Tyre options

Optional tires	Overall machine height	Overall machine width
Trelleborg - 460/70 R24 159A8 TH400	2.37 m	2.40 m
Trelleborg - 500/70 R24 164A8 TH400	2.39 m	2.43 m
Michelin - 15.5 R25 XHA	2.37 m	2.33 m
Nokian - 460/65 R24 159A8 Tri Steel	2.36 m	2.37 m

Options / Finishing

S : Standard / O : Optional / - : Not available

	Classic	Premium	Elite
General			
Self cleaning air prefilter	S	S	S
Auto reversing fan	S	S	S
"Active CRC" boom suspension	O	O	S
Hand throttle	O	O	S
Automatic wheel alignment	O	O	S
Additional fuel tank (25 l)	O	O	O
Manual rotating towing hitch	S	S	S
Automatic rotating towing hitch on counterweight	O	O	O
Ladder hitch with choice of hooks	O	O	O
Comfort			
Mechanical cloth-covered seat (Grammer)	S	-	-
Air suspension cloth-covered seat (GRAMMER)	O	S	-
Low frequency air suspension cloth-covered seat (GRAMMER)	O	O	S
Low frequency air suspension cloth-covered seat with heating (GRAMMER)	O	O	O
Tuner car radio (50 W)	S	-	-
Bluetooth car radio with integrated microphone (100 W)	O	S	-
Bluetooth car radio with extra microphone (100 W)	O	O	S
Manual air conditioning	O	S	-
Air conditioning with automatic adjustment	O	O	S
"Harmony" display	S	S	-
"Vision" display	O	O	S
Hydraulic			
Easy Connect System (ECS)	S	S	S
Continuous flow hydraulics	O	O	S
Attachment hydraulic locking	O	O	O
Return pipe to hydraulic oil tank	O	O	O
1 pair of pre-fitted Double Action rear hydraulic couplers	O	O	O
Electrovalve for 2 hydraulic functions (on boom head)	O	O	O
Hydraulic trailer brake	S	S	S
Intelligent Hydraulics	O	O	O
Regenerative Hydraulics	O	O	O
Electricity / Safety			
Audio warning on reverse movements	O	O	O
Front and rear work lights on cab (x4: 2 front + 2 rear)	S	-	-
Front and rear LED work lights on cab (x4 : 2 front + 2 rear)	O	S	S
Lateral wiper	S	S	S
Extra front wiper	O	S	S
Electric mirror with de-icing	O	O	S
LED + (4 extra work lights)	O	O	O
LED work lights on boom head (on fixed part) (x2)	O	O	O

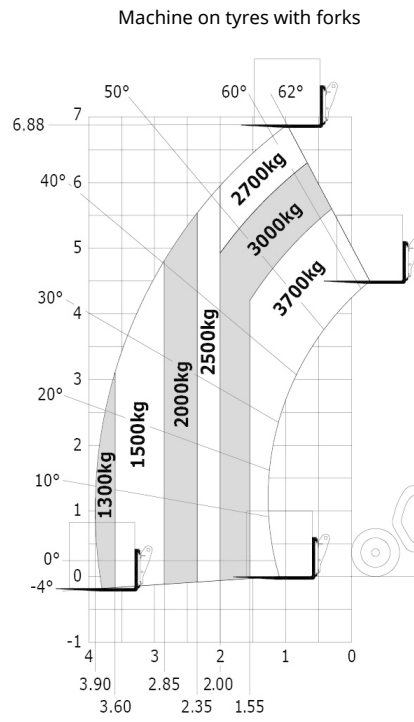

Rough terrain load chart (EN 1459 B)

Dimensional drawing

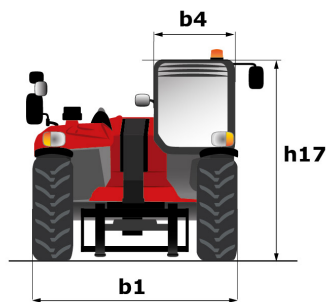
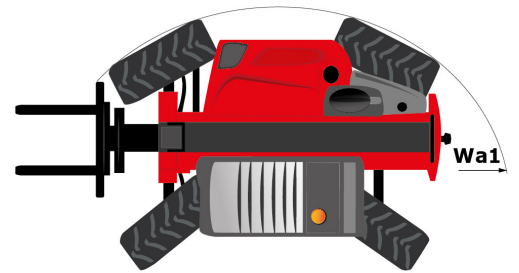
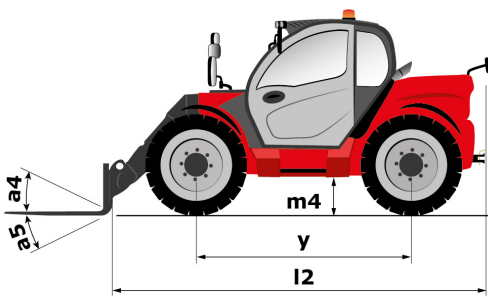

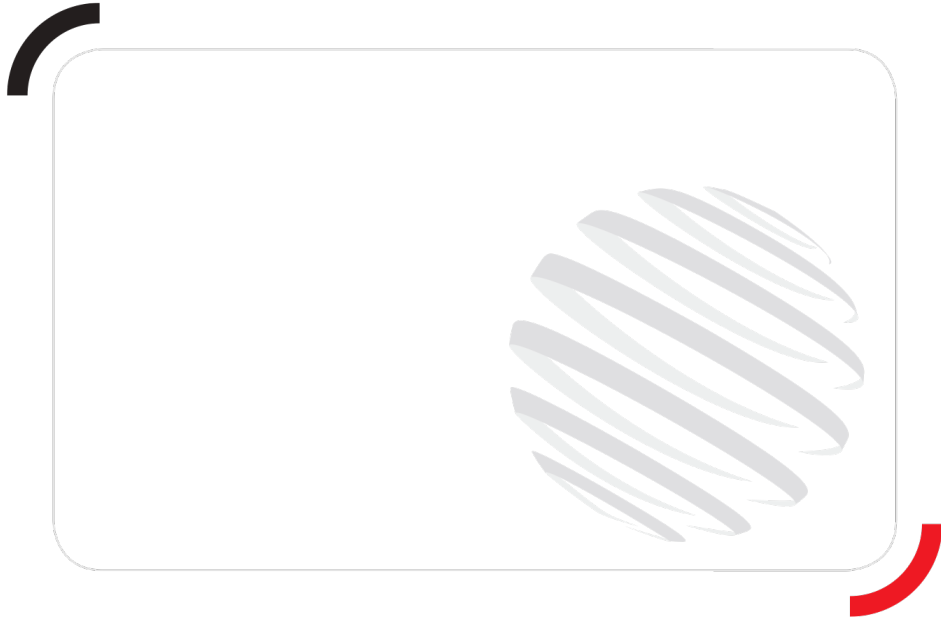

Siège Social
430 rue de l'Aubinière - 44150 Ancenis Cedex - France
Tel: +33(0)2 40 09 10 11 - Fax: +33 (0)2 40 09 10 97
www.manitou.com



This brochure describes versions and configuration options for Manitou products which may be fitted with different equipment. The equipment described in this brochure may be standard, optional or not available depending on version. Manitou reserves the right to change the specifications shown and described at any time and without prior warning. The manufacturer is not liable for the specifications given. For more information, contact your Manitou dealer. Non-contractual document. Product descriptions may differ from actual products. List of specifications is not comprehensive. The logos and visual identity of the company are the property of Manitou and may not be used without authorisation. All rights reserved. The photos and diagrams contained in this brochure are provided for information only.

MANITOU BF SA - Limited company with board of directors - Share capital: 39,547,824 euros - 857 802 508 RCS Nantes