

Standard Equipment/Optional Equipment

Standard Equipment

Sinergo®, the operator / truck interface:

Power assisted steering
 Long tiller with low mounting point
 Creep speed control
 Linde Safety-Lift
 End-of-stroke resistance
 Dedicated work station (with storage compartments)
 OptiLift® proportional lift system on the tiller head
 Mast protection (polycarbonate or steel mesh)
 Multifunction coloured display with Load Management warning indication as well as hourmeter, maintenance indication, battery discharge indicator and internal fault code indication

2,3 kW AC motor (maintenance free)
 CAN bus technology
 Vertical battery change 2 PzS or 3 PzS
 Positive steering (drive wheel) feedback
 Automatic speed reduction when cornering
 Electromagnetic emergency brake
 Key switch or LFMgo (PIN-code access)
 Cushion drive wheel
 Polyurethane single load wheels
 Single castor wheel
 Width over fork carriage: 560 mm, or 680 mm
 Fork carriage length / thickness: 1150 mm / 75 mm or 55 mm (preferred while using gitter box)
 Protection -10°C

Linde Load Management (Standard):

Automatic residual capacity calculation
 Operator warning when approaching the limits
 Traction speed is varied automatically in proportion to the steering angle for maximum safety

Optional Equipment

Linde Load Management Advanced:

On top of the Standard version, the system displays:
 - Current weight and height
 - The maximum limits it can handle and reach
 The acceleration is proportional to the steering angle

Initial lift
 Proportional speed control
 Ultra fast lifting (up to +40%)
 Double castor wheels
 Soft landing of forks (free of charge)
 Drive wheels: polyurethane, wet grip, cushion with tread, polyurethane with tread or non marking
 Load wheels: tandem polyurethane, tandem polyurethane gresable

Load backrests
 Lateral battery change 3 PzS
 Standard, Duplex or Triplex masts (Mast up to 5316 mm)
 Alternative fork carriage length / thickness: 950 mm / 75 mm or 55 mm (preferred while using gitter box)
 Linde Fleet Management: LFMaccess and LFMbasic
 Pack Clipboard
 Mobile or Fixed battery stand (for lateral battery change)
 Automatic battery watering system
 Built-in charger
 Cold store protection -35°C

Other options available on request



Pedestrian Pallet Stacker Capacity 1400 and 1600 kg L14, L16

Series 1173

Safety

The Linde pedestrian pallet stacker is a perfect fit for any stacking application. The unique Load Management® system calculates the residual capacity at all times and warns the operator when the truck is approaching its limit. Safety-lift can be used for lifting with the tiller vertical while safety is assured as both hands remain on the controls.

Performance

High operational efficiency is this truck's true strength with its 2,3 kW AC motor and capacity from 1400 to 1600 kg. The robust chassis structure gives this truck exceptional residual capacity. An upgraded version of the Load Management® system offers greater functionality by displaying information on load weight and lifting height.

Comfort

The OptiLift system, easy access to the controls and fingertip operation of the truck allow precise and comfortable handling. The proportional speed control option automatically reduces traction speed in relation to the distance between truck and operator.

Linde Material Handling



Features

Tiller & Tiller head

- With the soft fold back system, the tiller returns smoothly to the vertical position preventing impacts against the motor's cover
- Long tiller with low mounting point provides a large safety clearance between operator and chassis
- Easy-to-reach control buttons permit fingertip operation for utmost efficiency
- Wrap-around hand protection
- Twin grip steering control, operable with either hand for easy handling

Linde Load Management

- Standard or Advanced, the load management system assists control of residual capacity and stability
- Immediate calculation of load weight and lifting height for precise handling



Lifting System

- OptiLift mast control provides precise, fully proportional lifting
- Soft landing of the forks protects the load when lowering
- Initial lift version provides improved clearance on ramps and dock levellers
- Wide range of mast options available to suit any application



Multifunctional Display

- Important information about truck and the load
- Visual warning when residual capacity limit is reached
- Provides hourmeter, battery status and maintenance information



Brakes

- Automatic braking on release of traction butterfly or selecting the opposite direction
- Truck slows before coming to a stop, remaining under total control at all times
- Highly efficient electromagnetic brake applied by moving the tiller to fully up or down position
- Easy-to-reach emergency isolator on the top of the front cover

Steering System

- Electric power steering as standard ensures effortless driving
- Proportional speed control varies truck speed automatically in relation to tiller angle for safe operation
- Creep speed function allows for slow and highly maneuverable operation in confined areas with upright tiller
- End-of-stroke resistance on the tiller avoids accidental, abrupt braking

AC Motor

- Powerful, high torque 2,3 kW AC drive motor
- Moisture and dust-proof AC motor
- No rollback when starting on a slope
- Traction speed adjustable up to 6km/h, laden or unladen



Battery change

- Vertical battery change as standard
- Lateral change option includes:
 - Rollers inside the battery compartment to aid battery change
 - Lever initiates battery change preventing direct contact

Technical Data according to VDI 2198

		LINDE		LINDE	
Characteristics	1.1	Manufacturer		LINDE	LINDE
	1.2	Model designation		L14	L16
	1.2a	Series		1173-00	1173-00
	1.3	Power unit		Battery	Battery
	1.4	Operation		Pedestrian	Pedestrian
	1.5	Load capacity	Q (t)	1.4	1.6
	1.6	Load centre	c (mm)	600	600
	1.8	Axle centre to fork face	x (mm)	727	727
	1.9	Wheelbase	y (mm)	1304 ¹⁾	1304 ¹⁾
Weights	2.1	Service weight	(kg)	1200 ²⁾	1205 ²⁾
	2.2	Axle load with load, front/rear	(kg)	1006 / 1594 ²⁾	1026 / 1779 ²⁾
	2.3	Axle load without load, front/rear	(kg)	870 / 330 ²⁾	870 / 335 ²⁾
Wheels/Tyres	3.1	Tyres rubber, SE, pneumatic, polyurethane		V+P/P ³⁾	V+P/P ³⁾
	3.2	Tyre size, front		Ø 230 x 90	Ø 230 x 90
	3.3	Tyre size, rear		Ø 85 x 85 (Ø 85 x 60) ⁴⁾	Ø 85 x 85 (Ø 85 x 60) ⁴⁾
	3.4	Auxiliary wheels (dimensions)		Ø 150 x 50	Ø 150 x 50
	3.5	Wheels, number front/rear (x = driven)		1x + 1 / 2 (1x + 1 / 4) ⁵⁾	1x + 1 / 2 (1x + 1 / 4) ⁵⁾
	3.6	Track width, front	b10 (mm)	530	530
	3.7	Track width, rear	b11 (mm)	380	380
Dimensions	4.2	Height of mast, lowered	h1 (mm)	1990	1990
	4.3	Free lift	h2 (mm)	150	150
	4.4	Lift	h3 (mm)	2924	2844
	4.5	Height of mast, extended	h4 (mm)	3460	3380
	4.9	Height of tiller arm in operating position, min/max	h14 (mm)	750 / 1126	750 / 1126
	4.15	Height, lowered	h13 (mm)	86	86
	4.19	Overall length	l1 (mm)	1950 ^{2) 1)}	1950 ^{2) 1)}
	4.20	Length to fork face	l2 (mm)	800 ^{2) 1)}	800 ^{2) 1)}
	4.21	Overall width	b1/b2 (mm)	800	800
	4.22	Fork dimensions	s/e/l (mm)	71 x 180 x 1150 ⁵⁾	71 x 180 x 1150 ⁵⁾
	4.24	Width of fork carriage	b3 (mm)	780	780
	4.25	Fork spread, min/max	b5 (mm)	560 / 680	560 / 680
	4.26	Width between reach legs	b4 (mm)	255 / 375	255 / 375
	4.32	Ground clearance, centre of wheelbase	m2 (mm)	30	30
	4.33	Aisle width with pallet 1000 x 1200 across forks	Ast (mm)	2474 (2088) ^{6) 7)}	2474 (2088) ^{6) 7)}
4.34	Aisle width with pallet 800 x 1200 along forks	Ast (mm)	2434 (2288) ^{6) 7)}	2434 (2288) ^{6) 7)}	
4.35	Turning radius	Wa (mm)	1615	1615	
Performance	5.1	Travel speed, with/without load	(km/h)	6 / 6 ⁸⁾	6 / 6 ⁸⁾
	5.2	Lifting speed, with/without load	(m/s)	0.16 / 0.25 (0.4) ⁹⁾	0.14 / 0.22 (0.37) ⁹⁾
	5.3	Lowering speed, with/without load	(m/s)	0.45 / 0.45	0.4 / 0.35
	5.8	Maximum climbing ability, with/without load	(%)	11.0 / 24.0	10.0 / 24.0
5.10	Service brake		electric/mechanic	electric/mechanic	
Drive	6.1	Drive motor, 60 minute rating	(kW)	2.3	2.3
	6.2	Lift motor, rating at S3 15%	(kW)	3	3
	6.3	Battery according to DIN 43531/35/36 A,B,C,no		43 535 / B	43 535 / B
	6.4	Battery voltage/rated capacity (5h)	(V/Ah)	24 / 250	24 / 250
	6.5	Battery weight (± 5%)	(kg)	212	212
	6.6	Power consumption according to VDI cycle	(kWh/h)	1.36	1.36
Others	8.1	Type of drive control		LAC mit Mikroprozessor	LAC mit Mikroprozessor
	8.4	Noise level at operator's ear	(dB(A))	< 72	< 72

1) ± 0 mm = 2 PzS vertical; + 75 mm = 3 PzS vertical and 2 PzS/3PzS lateral
 2) Figures with battery, see line 6.4/6.5.
 3) Solid rubber + polyurethane / polyurethane
 4) Figures in parenthesis with tandem load wheels.
 5) (55x180x1150) Option Post pallet FC

6) Calculated with VDI 2198 (VDI 3597)
 7) Including a 200 mm (min.) operating aisle clearance.
 8) (± 5%)
 9) figures in parenthesis for optional „Lift Speed Booster“

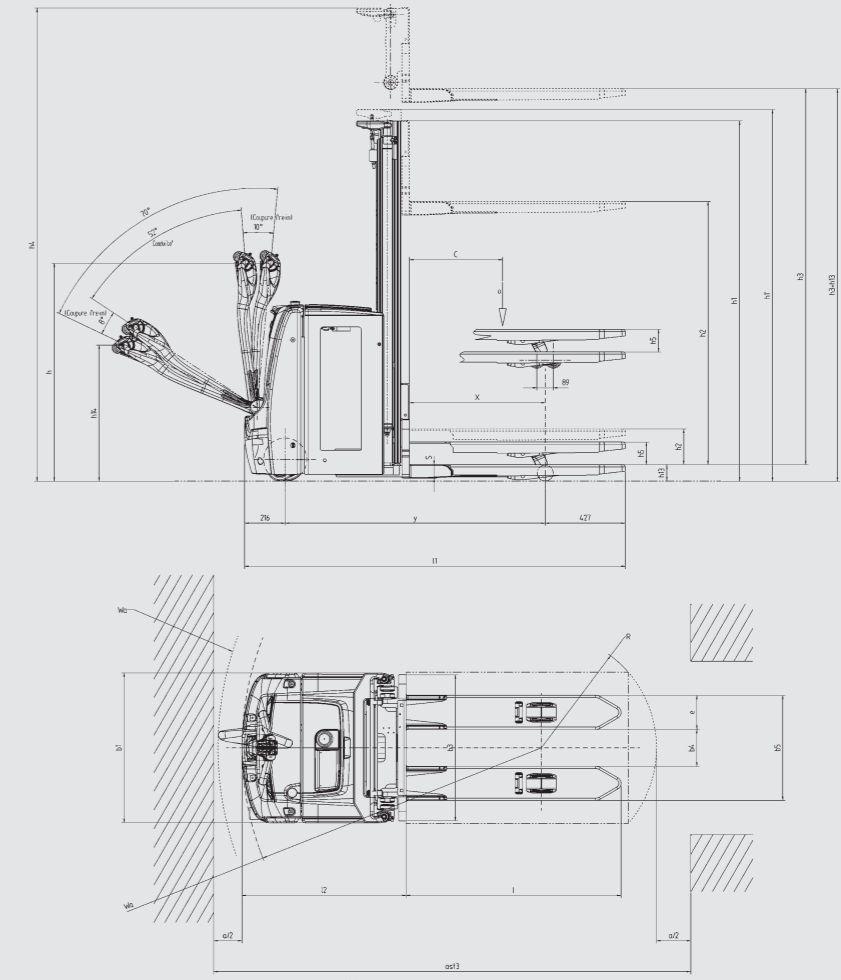

Mast (in mm)	-	1844 S	2344 S	2844 S	3244 S	3744 S	4144 S	4644 S	1844 D	2344 D
Lift	h3	1844	2344	2844	3244	3744	4144	4644	1844	2344
Lift + fork height	h9	1320	1570	1820	2020	2270	2470	2720	1320	1570
Height lowered	h1	1415	1665	1915	2115	2365	2565	2815	1415	1665
Height extended	h1'	1490	1740	1990	2190	2440	2640	2890	1415	1665
Free lift	h2	150	150	150	150	150	150	150	895	1145

Mast (in mm)	-	2844 D	3244 D	3744 D	4144 D	4644 D	3516 T	4266 T	4716 T	5316 T
Lift	h3	2844	3244	3744	4144	4644	3516	4266	4716	5316
Lift + fork height	h9	1820	2020	2270	2470	2720	1570	1820	1970	2710
Height lowered	h1	1915	2115	2365	2565	2815	1665	1915	2065	2265
Height extended	h1'	1915	2115	2365	2565	2815	1665	1915	2065	2265
Free lift	h2	1395	1595	1845	2045	2295	1145	1395	1545	1745

Other masts on request
 S=Standard, D=Duplex, T=Triplex