

JOG FORMA



User manual



The Wellness Company

Contents

Contents.....	2
Important safety instruction	3
Personal safety	5
Manufacturer and equipment identification.....	7
Technical data.....	8
Description of the equipment.....	10
Safety devices and warnings.....	11
Place of usage	13
Moving the equipment	14
Levelling.....	15
Electrical connection	16
Switching on and off	17
Maintenance.....	18
Aligning the treadmill	21
Easily solved problems	22
Technical Support Service.....	24
Storage	25
Scrapping.....	25
Monitoring the heart rate	26
Using Jog Forma.....	28

Important safety instruction

You should always consult with a qualified and licensed medical professional or healthcare practitioner before starting any nutritional, diet, stretching or exercise program. You are advised to investigate and inform yourself about any health related actions and choices you make.

Jog Forma is intended for commercial use.

Please read all instructions before using the equipment. These instructions were written to ensure your safety and to protect the unit.

When using an electrical appliance, basic precautions should be always followed, including the following.



DANGER

To reduce the risk of electric shock, always unplug the unit from the electrical outlet immediately after using and before cleaning or performing any maintenance tasks.

To reduce the risk of burns, fire, electric shock or injury to person, take the following precautions.

- The equipment should never be left unattended when plugged in. Unplug from outlet when not in use, before cleaning it, and before putting on or taking off electrical parts.
- Do not allow children unsupervised access to the equipment; parents and guardians must assume responsibility for the children in their care and avoid the occurrence of situations or usage for which the equipment was not designed. Children must be closely supervised when using the equipment, with careful attention paid to their mental and physical development. The equipment must under no circumstances be adapted or used as a toy.
- Close supervision by qualified personnel is necessary when the equipment is used by or near invalids or disabled persons.
- Use the equipment only for its intended use as described in the user manual. Only perform the exercises for which the equipment has been designed, following the instructions given in the manual. Any other use is to be considered improper and therefore dangerous.
- Do not use attachments not recommended by Technogym.
- Never operate the equipment if it has a damaged cord or plug, if it is not working properly, if it has been dropped or damaged, or dropped into water. In this case, contact the Technogym Technical Support service.
- Do not carry the equipment by power cable or use cord as handle.
- Keep the cord away from heated surfaces.

Important safety instruction

- Keep hands away from moving parts.
- Never drop or insert any object into any opening.
- Do not use outdoors. Do not leave the appliance outdoors, exposed to the elements (rain, sun, wind, etc.). Do not expose the appliance to water jets.
- Do not operate where aerosol (spray) products are being used or where oxygen is being administered.
- To disconnect, turn all controls to the off position, then remove plug from outlet.

 **WARNING**
Connect the equipment to a properly grounded outlet only. See grounding instructions.

SAVE THESE INSTRUCTIONS

Personal safety

Before starting any exercise you are advised to read the whole manual thoroughly and get to know the equipment's controls.

Jog can be used only after having a **medical check-up** for the specific type of exercise to be carried out and in compliance with Technogym's stated use conditions.

Before starting a workout program, consult a doctor for advice on any limits to observe when using the equipment.

Persons with specific physical complaints may use the equipment only under the strict supervision of a doctor specialised in that particular area.

If you feel ill during the workout (dizziness, chest pains, etc.), **stop exercising immediately** and consult a doctor.

If the message "HIGH HEART RATE" appears during the exercise, your heart rate is too high and you should **slow** the exercise **down**.

At the beginning of each exercise, make sure you are in **the correct position**, and that none of the parts of the equipment are in your way.

Choose suitable exercises for your physical characteristics and state of health, starting out with light loads.

Do not overexert yourself or work to exhaustion. Incorrect or excessive exercise may cause serious physical harm or even death. If you feel any pain or abnormal symptoms, stop your workout immediately and consult your physician.

Wear proper exercise clothing and shoes during a workout, no loose clothing. Tie long hair back. Keep garments or towels away from moving parts.

During use people must remain at a safe distance.

Do not use the equipment in presence of small children or pets.

Completely assemble the equipment before using it. Check the unit before each use. Do not continue to operate the equipment when it is not working properly.

Assemble and operate the equipment on a solid, level surface.

Keep all electrical components, such as the power cable and I/O switch, away from liquids to prevent shock.

Maintain the equipment in good working condition. If there are signs of wear, contact the Technogym Technical Support service.

Do not attempt to service the equipment yourself other than the maintenance instructions found in the manual.

Do not place anything on the casing, the treadmill or the control panel.

Personal safety

The equipment **must not** be placed close to heat sources or close to sources of electromagnetic waves (e.g. televisions, electrical motors, aerials, cellphones, etc.).

Although the equipment has been designed and built in accordance with health and safety requirements, there are some zones in which there are unseen hazards. You must be very careful about possible upper and lower limb crushing hazards.



WARNING

Technogym s.p.a. will be held responsible for its equipment only if the following precautions are observed:

- **the equipment must be used as specified;**
- **the User manual must be read thoroughly throughout;**
- **the place of installation must meet the requirements stated in the User manual;**
- **the electrical system must conform to the standards and legal requirements in the country of use;**
- **the installation, maintenance and setting must be done by qualified Technogym staff or persons authorised by Technogym;**
- **suitable clothing must be worn;**
- **towels and other items must not be put on the equipment.**

Technogym is not responsible for any damages due to any failures or damage caused by unauthorized service, misuse, accident, negligence, improper assembly or installation, debris resulting from any construction activities in the product's environment, rust or corrosion as a result of the product's location, alterations or modifications without Technogym's written authorization or for failure on your part to use, operate and maintain the products as set out in this User Manual.

Manufacturer and equipment identification

The equipment identity label gives the present information.

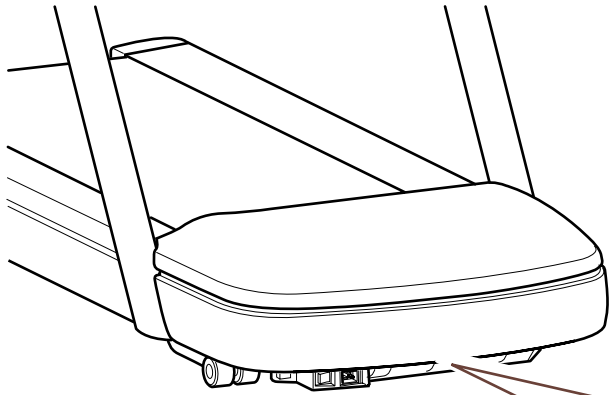

- Manufacturer's name and address
- Place of manufacture
- Description of product
- Electrical specifications
- Tells you to consult the User manual
- Serial number and date of manufacture
- Product model

Technical data

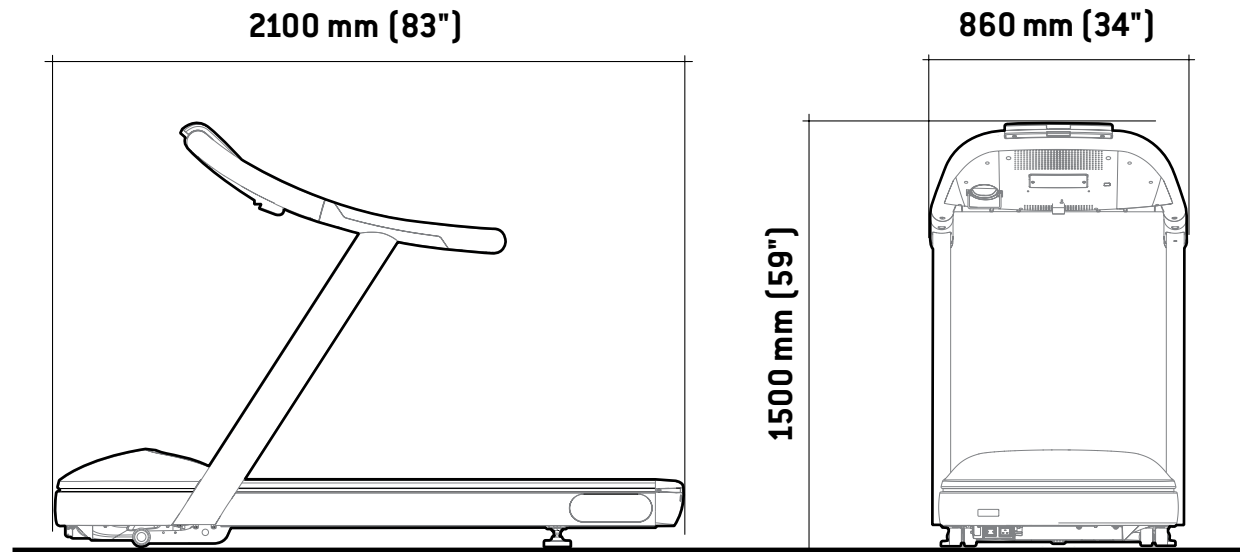

Technical data

	Jog Forma DEJ43LQ	Jog Forma DEJ4ALQ
Power supply	200÷240 Vac 50/60 Hz	100÷240 Vac 50/60 Hz
Power input	1600 W	1600 W
Motor peak power	4400W (6Hp)	4400W (6Hp)
Weight of equipment	165 kg (364 lb)	165 kg (364 lb)
Maximum user weight	180 kg (397 lb)	180 kg (397 lb)
Speed	0.4÷18 km/h (0.25÷11 mph)	0.4÷18 km/h (0.25÷11 mph)
Gradient	0÷15%	0÷15%
Noise level	Less than 80 dB	Less than 80 dB
Protection grade	IP 20	IP 20
Operating temperature	from +5°C (+41° F) to +35°C (+86° F)	from +5°C (+41° F) to +35°C (+86° F)
Electrical isolation class	Class I	Class I
Maximum capacity of water bottle-holder	2 kg (4 lb)	2 kg (4 lb)
Product class	SB	SB
Manufacturer	Technogym s.p.a. via Calcinaro 2861 - 47522 - Cesena FC	Technogym s.p.a. via Calcinaro 2861 - 47522 - Cesena FC

Ordinary appliance, not waterproofed.

Jog Forma is a class A equipment. In residential environments this equipment may cause radio interference. In this case the user must employ adequate measures.

Description of the equipment

- 1 - **Control panel.** Controls all available functions, from setting up workout programs to viewing messages and related workout information. Please see the control panel's manual to see how it works.
- 2 - **Treadmill belt.** Is a correctly cushioned running surface.
- 3 - **Side handgrips.** A safe point for support when getting on to the equipment, or if you lose your balance. Can be held when walking with large strides.
- 4 - **Footrests.** For getting on and off the equipment. By moving your feet from the treadmill belt to the footrest, you can take a short rest if you are tired or in danger.
- 5 - **Bottle-holder.** For standing the water bottle or other useful items on during the workout.
- 6 - **Object holder.** For placing magazines, books or tablets and other electronic devices. Tablets can be firmly fixed as shown in the figure.
- 7 - **Hand sensor.** The metal plate sensors permit constant heart rate monitoring.

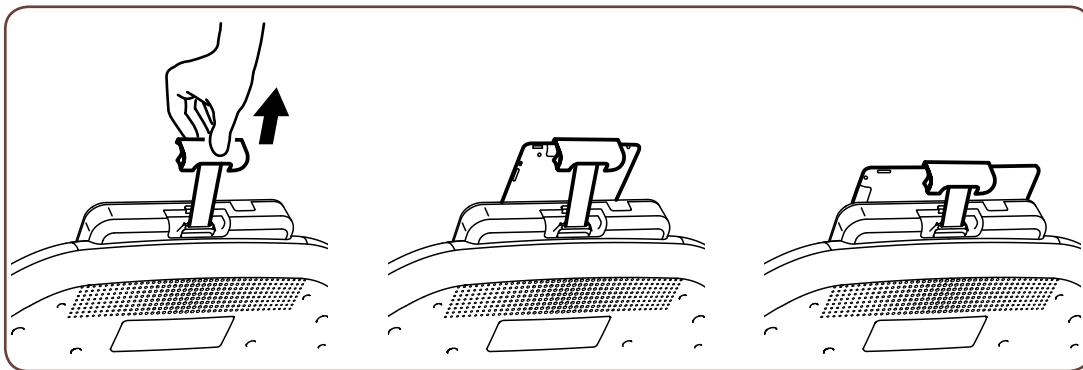
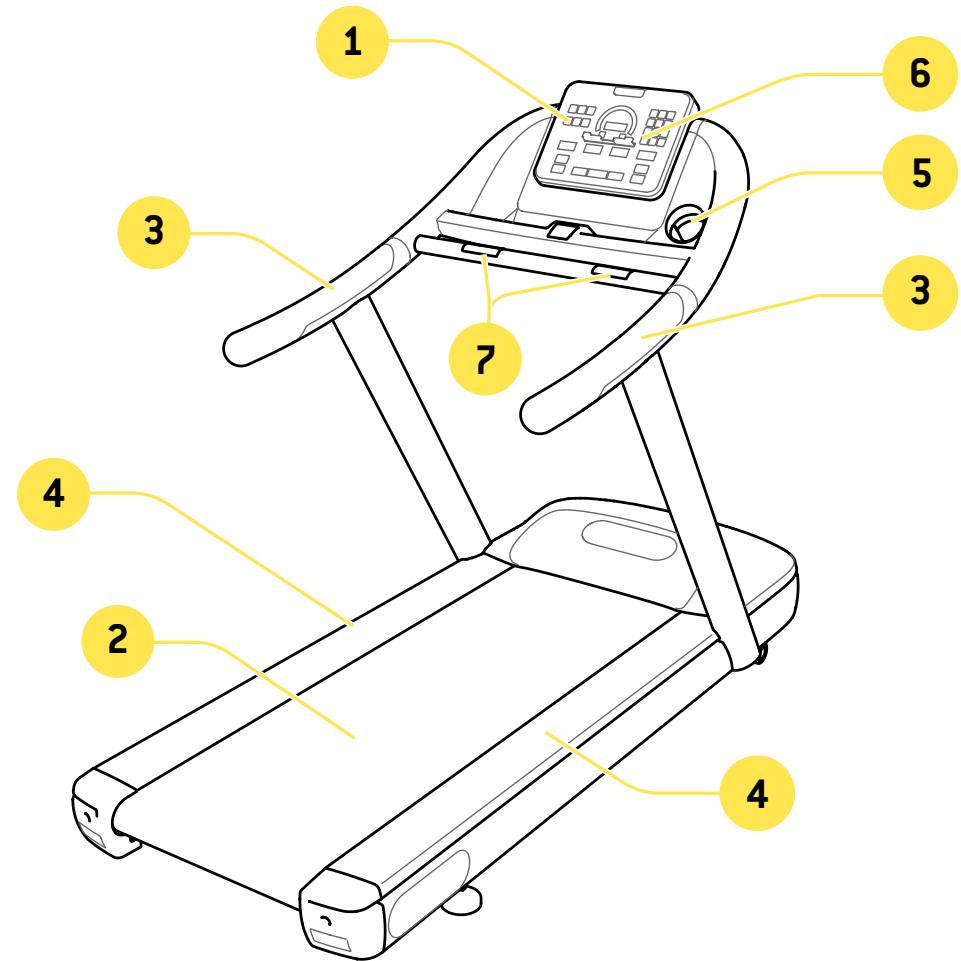

Safety devices and warnings

Emergency Stop button (A).

Located under the control panel, used to stop the equipment immediately in the event of an emergency.

A cord connects the switch to a clamp (B) that must be attached to the user's clothing. As a result, if the user moves too far from the control panel, the switch pops out and stops the equipment without having to touch the controls.

To reset all the equipment's functions, return the switch to its original position, then press any key.

To return the clamp in its seating, wind the cord in the direction shown in the figure.



WARNING

Before using the equipment check that the switch is in perfect working order and attach the clamp to the clothing.

User Present Function

The user present function is a safety function which stops the belt if it is moving without any person walking or running on it.

This function is activated if the belt is at a speed greater than or equal to 3 km/h. If no user is detected for 30 seconds when at a speed of 3 km/h or more, the belt stops and the exercise is paused.

At minimum speed, the user is detected only if they weigh at least 50 kg.

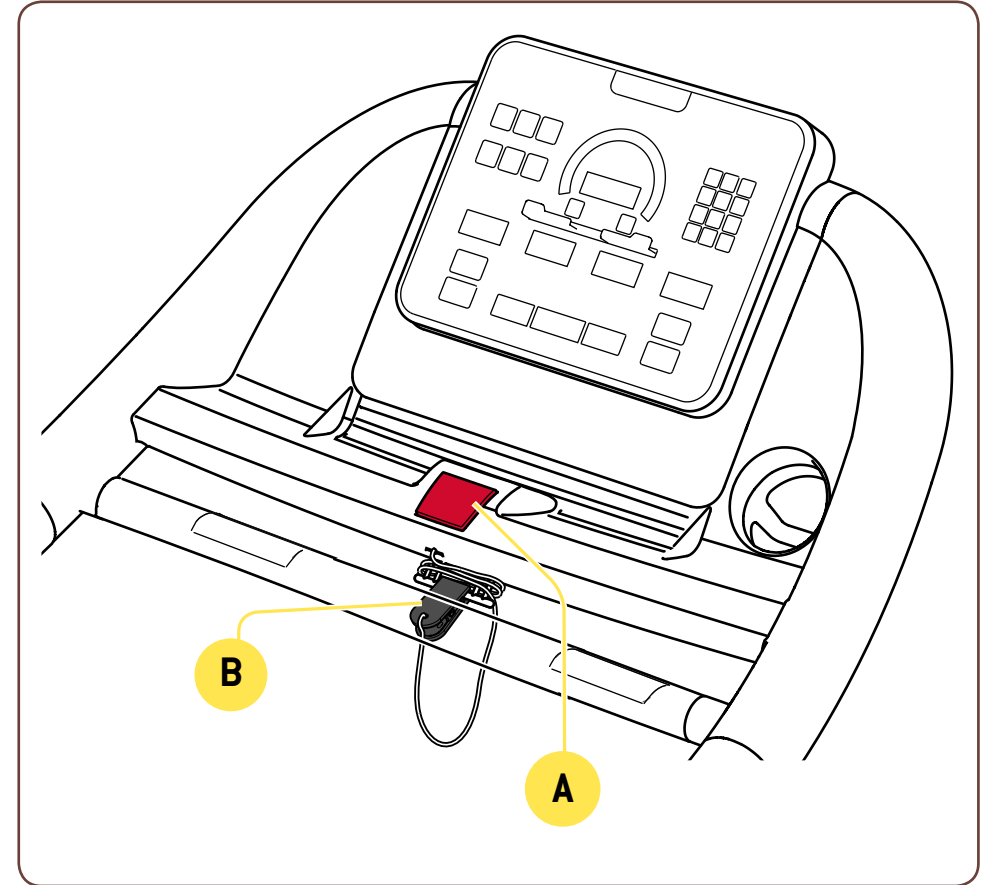

Safety devices and warnings

Circuit breaker (C). Protects the electrical components of the equipment. When power surges, the protection device opens, thus preventing damage to the electronics inside.

Main switch (D). Turns the equipment's power on and off.

Marking on the treadmill belt (E). The marking on the two sides of the treadmill belt indicates if the treadmill is moving.

Product immobilisation

To prevent unsupervised use of the product, remove the power supply cable (F) and keep it in a safe place.

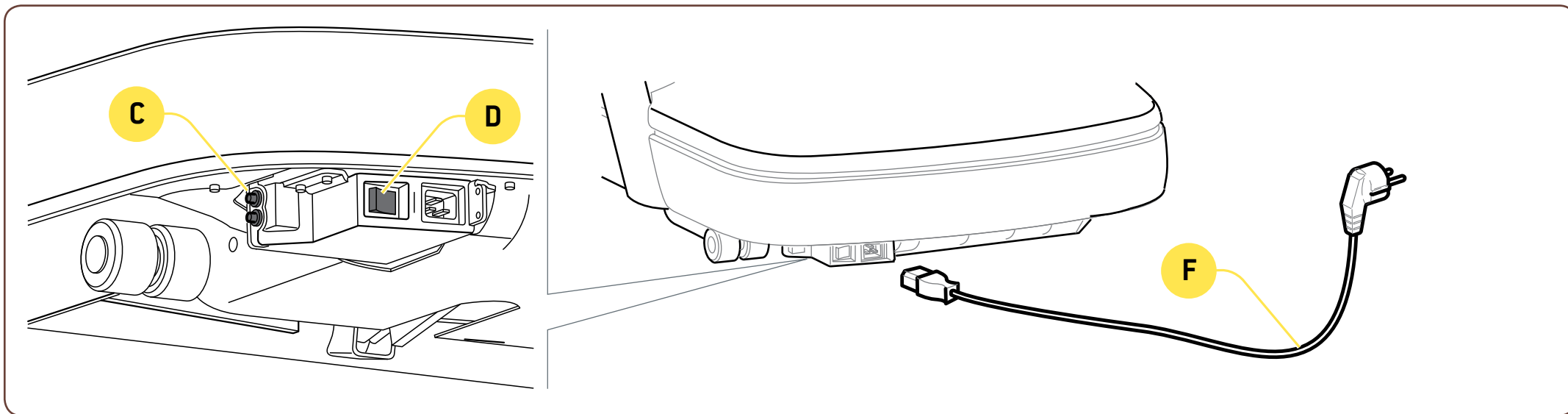
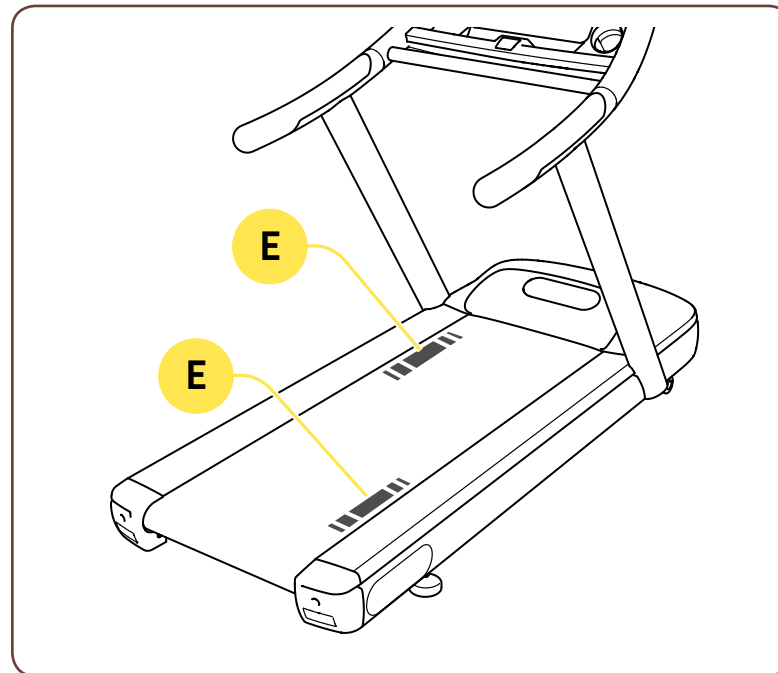

Place of usage

To guarantee safe, comfortable and effective use of the unit, it must be installed in a place which complies with certain specific requirements; in particular, before choosing where to install the unit we recommend that you check that the following conditions are available:

- a **temperature** between +10°C and +25°C;
- sufficient ventilation to maintain a **humidity** level between 20% and 70%, when the equipment is in use;
- adequate **lighting**, so that the workout takes place in pleasant and relaxing conditions;
- a safety **clearance** of 2 x 1 m, as shown in the illustration;
- a flat, stable and vibration-free surface, and strong enough to bear the weight of the equipment plus user.

The place of installation must comply with all binding regulations.

Do not expose the equipment to direct sunlight.

Do not install the equipment in areas with high humidity levels, for example close to swimming pools, whirlpools or saunas.

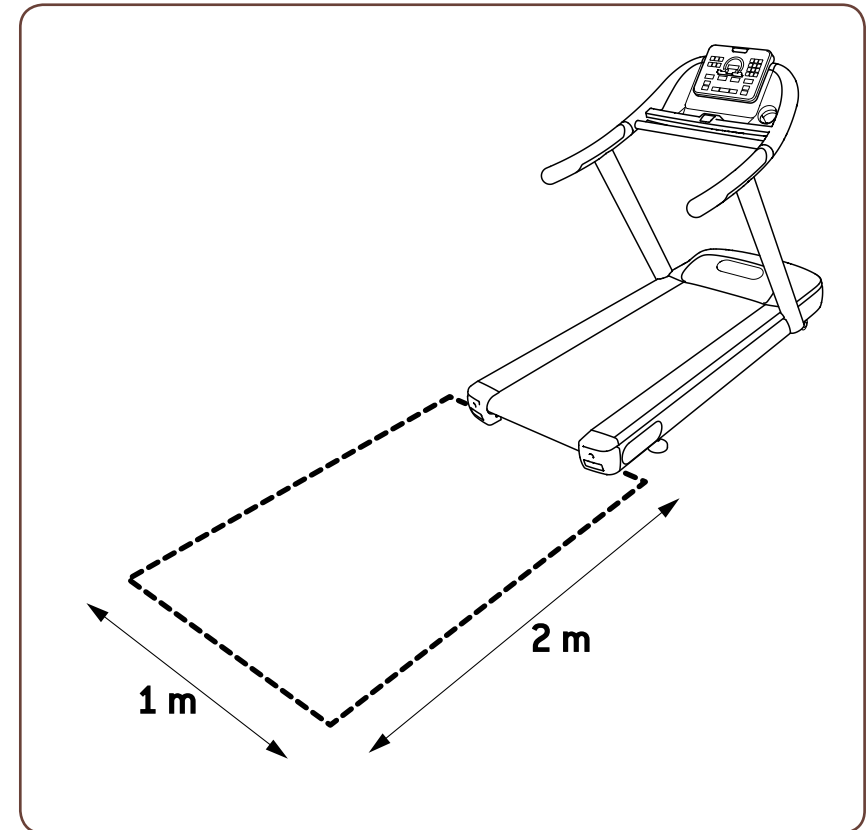

Moving the equipment



WARNINGS

Move the equipment with great care to avoid it tipping over.

After moving the equipment always check that it is level in order to guarantee the correct working.

Jog Forma has fixed front wheels.

To move the equipment, lift it up slightly, as shown in the illustration, and push it forwards and backwards.

Given the weight of the equipment, we recommend that more than one person be involved in lifting it.



WARNING

When lifting, it is recommended to grip the frame and not the plastic parts.

If flooring conditions prevent use of the wheels, normal moving procedures must be employed.

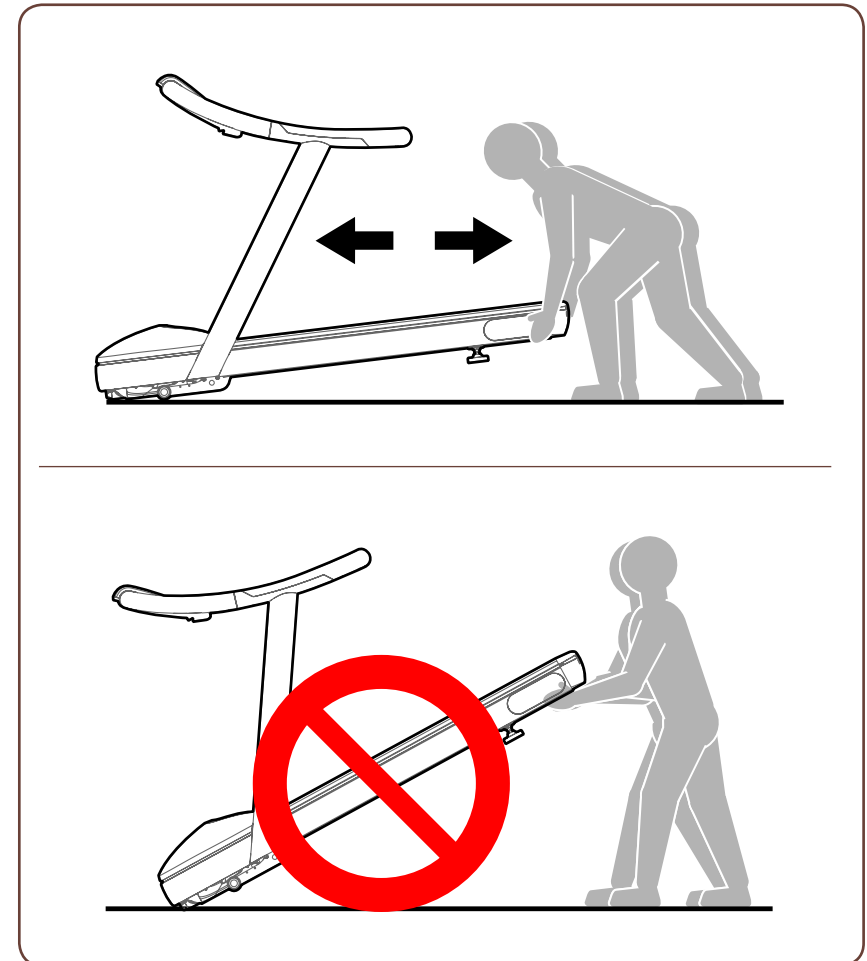

Levelling

Before use, check that the unit is level.

The equipment is levelled by adjusting the rear foot on the side shown in the illustration.

- Loosen the locknut (**B**).
- Screw the foot (**A**) in or out until the frame is in a stable position.
- Tighten up the lock nut (**B**) after adjusting.

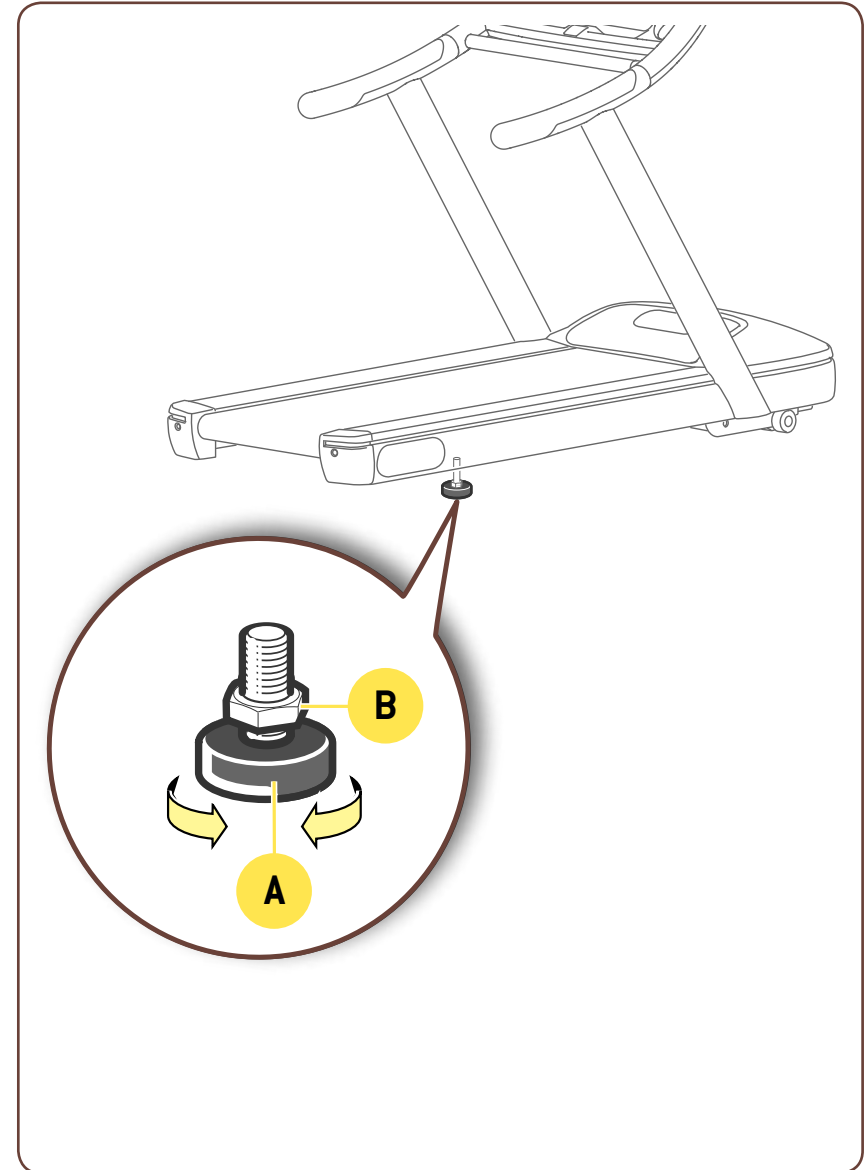

Electrical connection

Before connecting the equipment to the mains power supply, ensure that the electrical installation complies to binding regulations. Check the mains power supply specifications on the equipment identity label.



WARNINGS

The wall socket must be located in a place where the plugging and unplugging can be done easily and safely.

When plugging in, the main switch on the equipment must be in the 0 position (i.e. the equipment must be switched off).

Check the state of the power supply cable periodically.

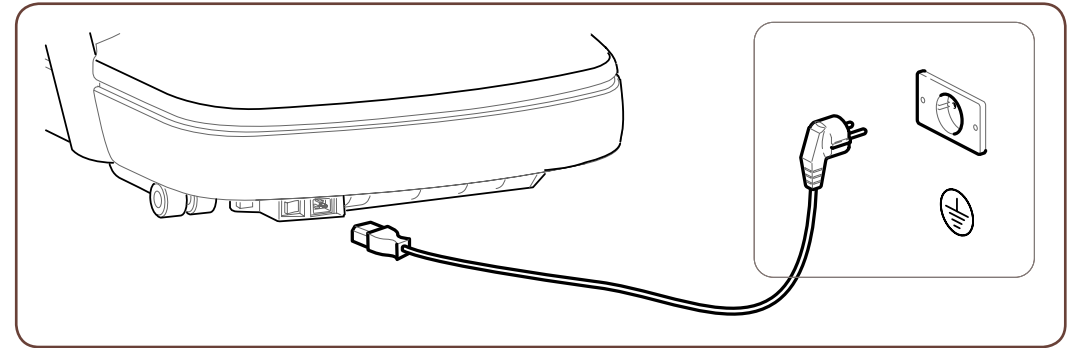

The power cable is supplied with the product.

Plug the power cable first into the equipment socket and then into the wall socket.

The product must be grounded. If it should malfunction or breakdown, grounding provides a path of least resistance for electric current to reduce the risk of electric shock. The product is equipped with a cord having an equipment-grounding conductor and a grounding plug. The plug must be plugged into an appropriate outlet that is properly installed and grounded in accordance with all local codes and ordinances.



WARNINGS

The power supply socket must be grounded . If not, a ground connection must be installed by a qualified electrician before connecting the equipment to the electricity mains.

Improper connection of the equipment-grounding conductor can result in a risk of electrical shock. Check with a qualified electrician or serviceman if you are in doubt as to whether the product is properly grounded. Do not modify the plug provided with the product; if it will not fit in the outlet, have a proper outlet installed by a qualified electrician.

Switching on and off

To turn the equipment on, switch the main switch to the “I” position (on) .

After a quick system check (reset), the equipment is ready for use.

To turn the equipment off, switch the main switch to the “0” position (off).

The equipment must be switched off only at the end of the exercise, when in standby.

If the equipment is not expected to be used for a long time, as well as turning it off you should also pull the plug out of the wall socket.



WARNING

The switch is for turning the equipment on and off but does not isolate it completely from the mains voltage, even in the “0” position (off). For complete isolation you must unplug the power supply plug.

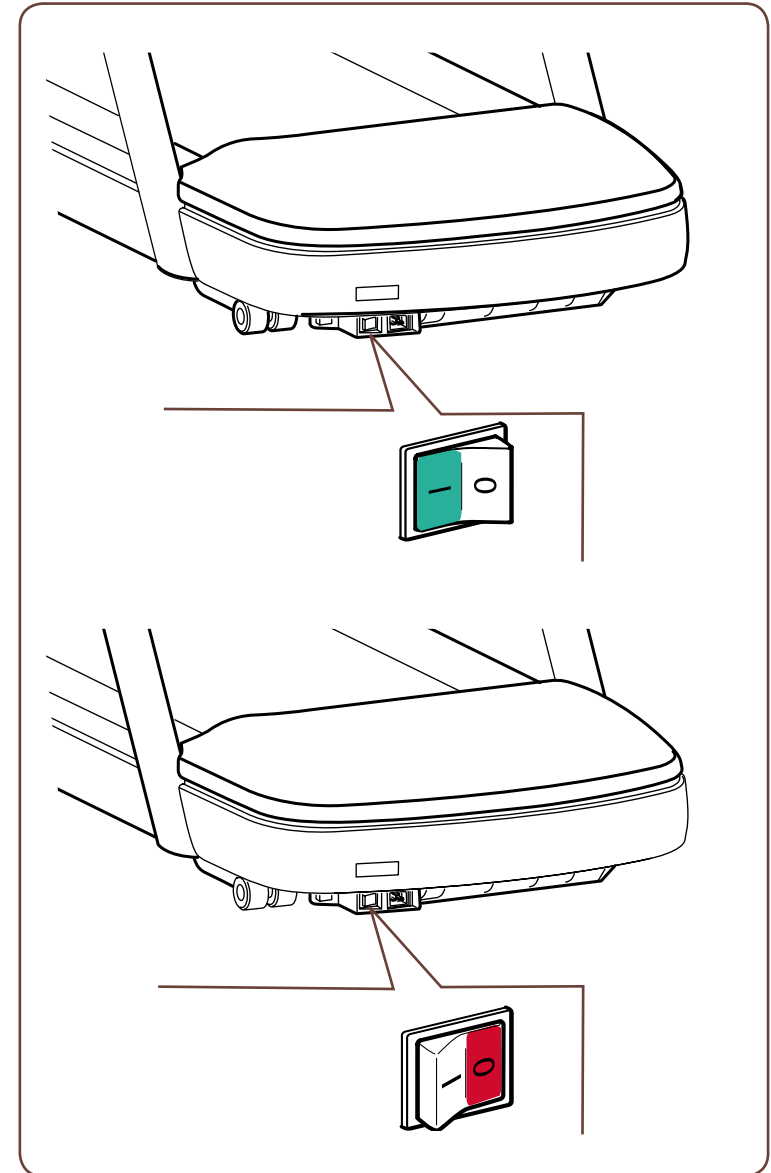

Maintenance



WARNINGS

The safety of the equipment is assured only on the condition that it is carefully inspected every two weeks for any signs of damage and/or wear.

Replace defective and worn components immediately, or alternatively remove the equipment from service.

For maintenance actions not described in this manual, call in the Technogym Technical Service.

Cleaning and looking after the equipment

The equipment should always be kept clean and free of dust, in accordance with normal hygiene and sanitary rules.

To clean the **control panel**, proceed as follows:

- turn the equipment off by switching the switch to **0**;
- unplug the equipment power cable from the wall socket;
- clean the control panel with a damp, but not wet, cloth.

Every week, clean **the equipment completely**:

- turn the equipment off by switching the switch to the **0** position;
- unplug the equipment power cable from the wall socket;
- clean the external parts with a damp sponge;
- raise the treadmill to the maximum gradient and clean around the lower guard and floor with a vacuum cleaner;
- clean the tread surface while it is running, using a clean nylon/synthetic brush or broom.

Do not use chemicals or solvents. Do not use abrasive products on polished parts.

Do not rub too hard on the control panel.



WARNINGS

The routine maintenance, adjustment and lubrication jobs must be performed by the Technogym Technical Support Service.

Before starting any job, turn the equipment off by switching the switch to the "0" position and unplug the power cable from the wall socket.

Every month:

- check the state of wear of the **treadmill**;
- clean the **motor compartment** and the **dust panel**.

Annually check the state of wear of the **treadmill transmission belt**.

Dust panel

The dust panel is positioned between the treadmill and the motor compartment and acts as a guard against external agents pulled in by the treadmill as it runs. Clean the dust panel and the surrounding area every month: remove the guard, extract the panel from its guides and clean it with a vacuum cleaner. For safety reasons, always replace the dust panel.

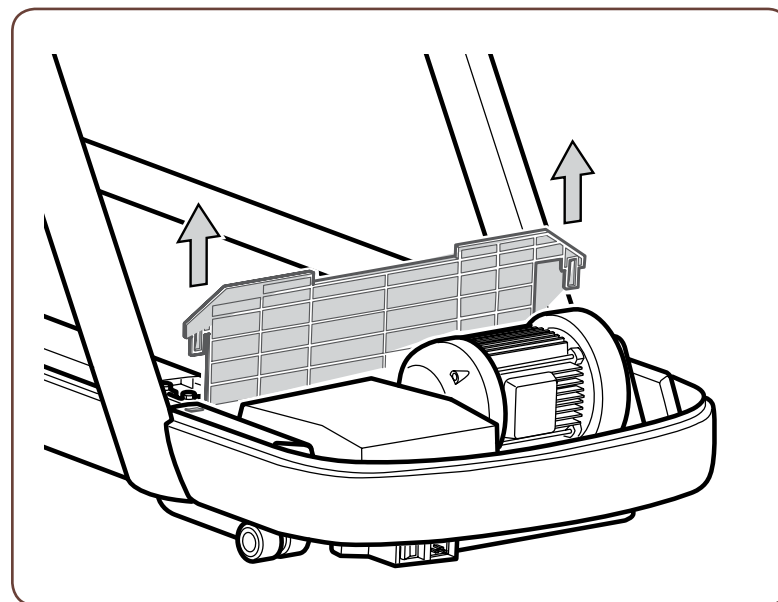
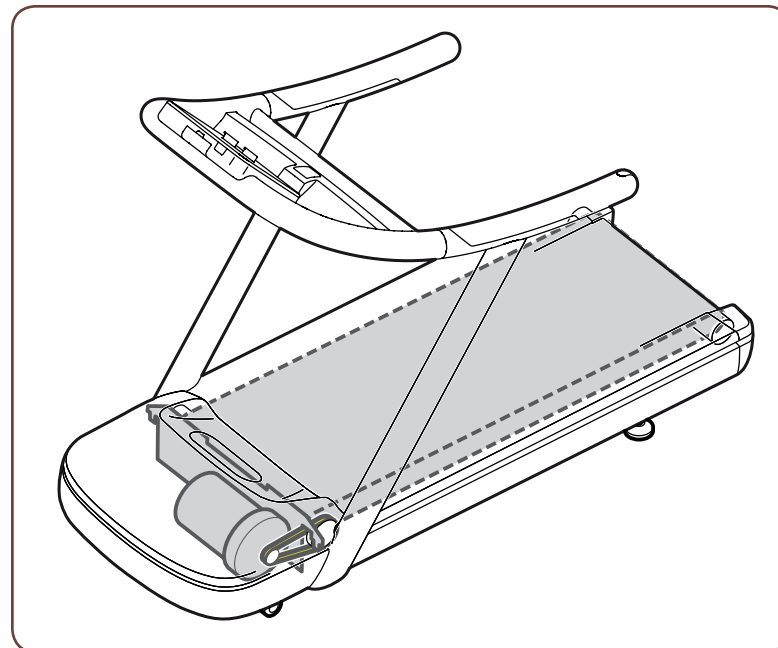

Emergency button

Check the condition of the emergency push button each month:

- Ensure that the cord and the spring are present and in good condition.
- Check the condition of the emergency push button.
- With the rotating belt in motion at 5 kph pull the cord with the spring to trigger the emergency push button and ensure that the belt stops.
- With the rotating belt in motion at 5 kph press the emergency push button to ensure that the belt stops.

If the emergency push button does not work properly place the product out of service and contact Technogym Technical Support Service.

to replace defective or damaged components contact the Technogym Technical Support Service.

Aligning the treadmill

When the equipment is running the treadmill must be centrally aligned in relation to the frame. If it tends to move to the right or left or is not centrally positioned, it needs aligning.

The alignment is done with the equipment running.

Set the adjustment screw (A), located at the back of the equipment, opposite the control panel support riser, so that the belt is centrally aligned with the back roller.

The treadmill realigns **slowly**: turn the adjustment screw 1/4 or 1/2 a turn and then check the result before turning it again.

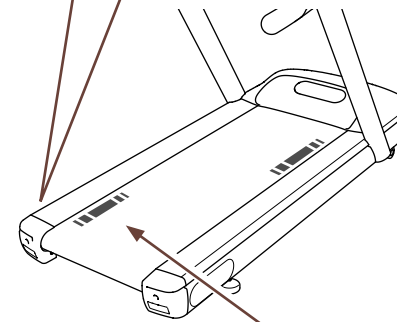
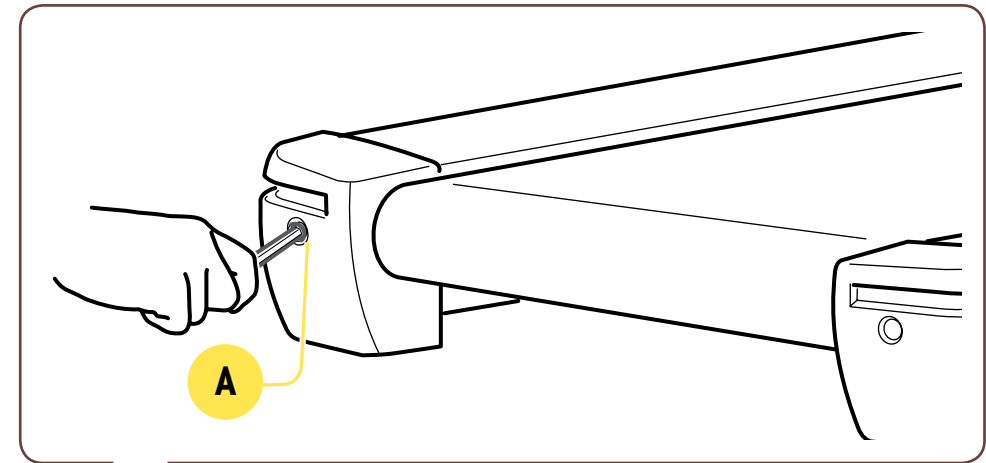

Maximum allowed running surface lateral position:
17 mm ± 5 mm

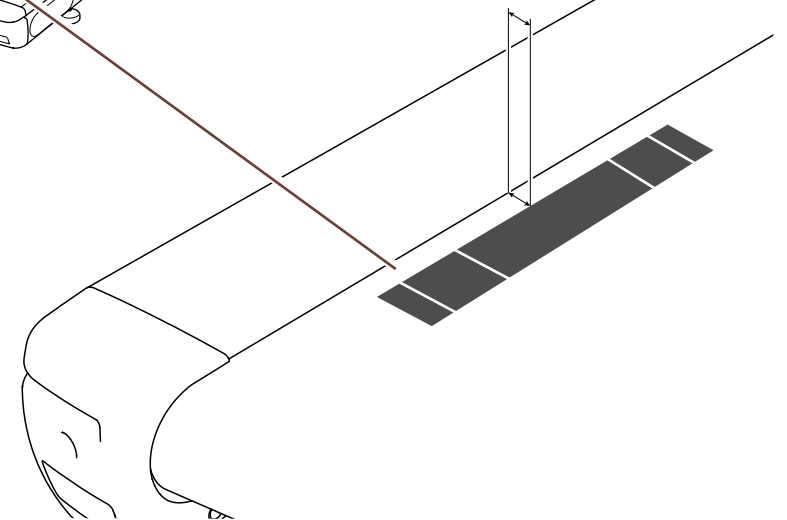

Easily solved problems

The following table lists a series of problems that may arise during normal use of the equipment. If the solutions given don't solve the problem, or if the problems are different, ask for help from the Technical Support Service.

Problem	Cause	Remedy
Equipment doesn't switch on	Power supply cable not plugged in	Plug the power supply cable into the wall socket
	Mains power failure	Check the power supply in the mains socket in question by plugging in another appliance that definitely works
	Power supply cable damaged	Contact the Technogym Technical Support Service
	Power supply cable connector not plugged into equipment	Plug the connector in
	The main switch is off	Switch on the main switch
	The Circuit breaker is open	Check that the two keys next to the switch are closed, by pressing them fully down
Excessive noisiness	Equipment not properly levelled	Check the position and level with the rear adjustment foot
Data incorrect or unreliable with equipment running	Equipment next to source of radio interference (e.g. electrical domestic appliance)	Move the equipment to another place or move the sources of interference

Easily solved problems

Problem	Cause	Remedy
Problems in reading heart rate	Other transmitters situated nearby	Move the equipment far enough away to stop signal interference (minimum distance between two units cm 80)
	Strong radio interference sources nearby	Find the interference source (e.g. electrical domestic appliance) and move it away or move the treadmill
	Worn chest band	Replace the chest band
	Chest band not making proper skin contact	Dampen the inside of the chest band with water



WARNING

There are high voltages inside the motor compartment, therefore the guard must be removed by authorised personnel only; only authorised personnel can carry out internal repairs.

Technical Support Service

The Technogym Technical Support Services provides:

- telephone consultation
- information about which services are covered by the warranty and which must be paid for
- on-site servicing
- supply of original spare parts.

Technical Support Service
Technogym s.p.a.
Via Calcinaro 2861, 47521 Cesena Italy
tel: +39 0547 56047
<http://www.technogym.com/Support>

When you contact the Technogym Technical Support Service you must give the following information:

- equipment model,
- date of purchase,
- serial number,
- precise description of the problem.

 **WARNING**
Work on the equipment by persons unauthorised by Technogym invalidates the warranty.

Technogym supplies the electrical and wiring diagrams to companies with technical support.

Storage

If a long period of disuse is expected, you are advised to store the equipment in the following way:

- in a dry, clean place, covered with a cloth to protect it from dust
- at a room temperature between +10°C and +25°C and relative humidity between 20% and 90%.

For better storage, use the **original packing materials**.

Disposal

It is always good practice to ensure that the unit can never constitute a hazard; therefore do not leave the equipment where children may play with it. For this reason, when it is not used for long periods it must be turned off by disconnecting the power cable.

Do not dump the equipment in the environment, or in public or private areas accessible to the public.

The equipment is made from recyclable materials such as steel, aluminium and plastic, which must be disposed of in the manner required by the urban refuse collection regulations in force, by specialised urban hygiene and environmental firms.

Electrical and electronic waste must not be put out for normal waste collection. A specific waste collection system is provided for with this type of product, in conformity with applicable legislation requiring appropriate handling, recovery and recycling.

Unauthorised dumping or disposal of electrical and electronic equipment or improper use of the same can cause serious damage to the environment and human health.

Following measures implemented by the member states of the European Union, private citizens resident in the EC can take their used electrical and electronic equipment to authorised collection centres for disposal.

If the product is used commercially, contact your reseller or Technogym Customer Service in your country to arrange collection and disposal of the electrical or electronic waste.

Contact the local authorities for disposal of electrical or electronic waste in countries outside the European Union.

Average product lifetime: 10 years.

Reading the heart rate

The equipment is able to measure heart rate trends, in two different ways:

- with a device applied to the handle (hand sensor), that switches on when you grip the handles in the sensor region;
- with a chest band with a heart rate transmitter (Polar T31).

There must be no more than one transmitter in the reception range: otherwise the receiver may receive different signals at the same time and give incorrect heart readings. If there are several equipment units with heart rate receivers in the same area, the recommended minimum distance between them is 80 cm.

Heart rate readings will not be accurate near electromagnetic radiation sources (TVs, cellphones, etc.).

Should you have any doubts about the accuracy of the readings, contact the Technical Support Service.

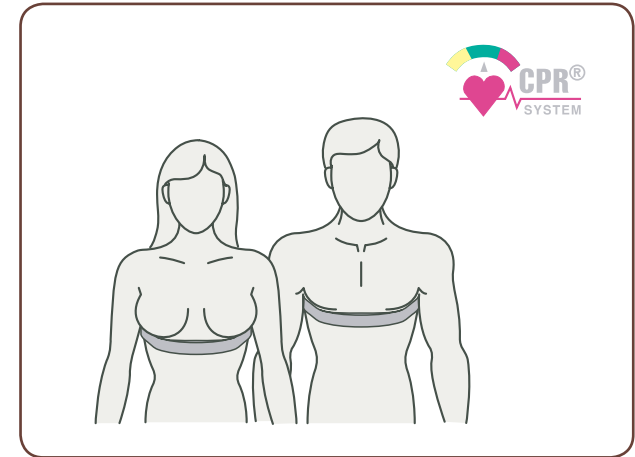

WARNINGS

During a workout it is very important that your heart rate never goes above 90% of your maximum rate (unless you are an athlete engaged in competitive sport).

The sole function of the heart rate monitor is to display the heart rate during exercise and cannot be used for medical cardiac diagnoses of any kind. The heart rate shown on the display is purely indicative and cannot be considered absolutely certain.

The following table shows the optimum heart rate levels in relation to age and the goal to be achieved. Theoretical maximum heart rate (100%) is calculated on the basis of age using the formula: $HR\ Max = 207 - 0.7 \times age$ (R. L. Gelish et alii, *Med Sci Sports Exerc.*, 2007 May, 39 (5): 281).

Reading the heart rate





To read the graph, simply find your age on the horizontal axis and scan up the vertical until you reach the 60%, 70% and 90% values.

Aerobic exercise performed at a heart rate **between 60% and 70%** mainly burns fat as an energy source.

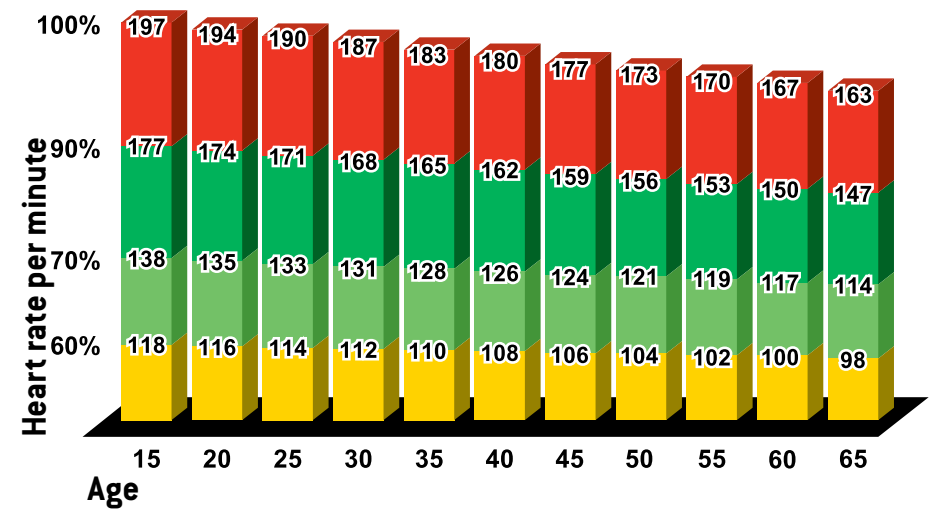
When doing aerobic exercise at a heart rate of **70% to 90%** the cardiocirculatory component prevails.

For example, if someone aged 30 wants to burn off fat, the heart rate during exercise should be kept to between 112 (60%) and 131 (70%); if he or she wants to improve cardio-respiratory capacity, the heart rate should be kept to between 131 (70%) and 168 (90%).



-  Prevalent use of sugars.
Training for athletes who take part in competitions (with medical certificate).
-  Combined use of fats and sugars.
Significant improvement of aerobic efficiency.
-  Prevalent use of fats and increased use of sugars.
Moderate improvement of aerobic efficiency.
-  Prevalent use of fats and little use of sugars.
Limited improvement of aerobic efficiency.

Using Jog Forma



WARNINGS

Jog Forma is to be used solely for its intended purpose, i.e. to simulate walking and running. Any other use is considered improper. It is the user's responsibility to ensure that the product being used does not interfere with any other mobile goods during use.

Step on the treadmill from the rear, looking forward, and put your feet on the footrests on either side. In this rest position hold on to the side grip with one hand, using the other hand to operate the control panel.

When the treadmill starts up, hold on to the grips with both hands and start walking slowly.

The grips make it safer when you first use the equipment; later on, however, it's better to walk or run without any support, to improve your balance and posture.

At a speed of about 6-7 km/h, the fast walking becomes a gentle run, with gradually lengthening steps. The speed will increase gradually as you feel more sure and stable.

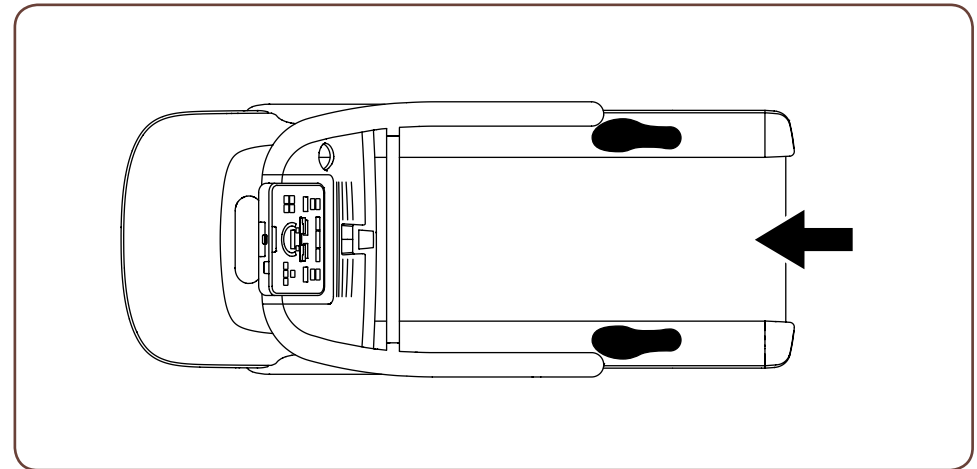

Using Jog Forma

Do not lean too far forward or back. The correct position is with your head up, shoulders aligned with your hips, arms loose with elbows at 90°, looking straight ahead as if at a point 5 - 6 metres away.

The stepping pace must be regular, with legs and feet parallel to the treadmill centre line.

To rest or get off the equipment without stopping the treadmill or in any case without touching the controls, you just have to grip the handgrips and move your feet onto the side footrests.

To get off the device in an emergency, grasp the side handgrips, support your weight on them and move your feet onto the footrests. Then get off the equipment.



WARNINGS

Walking or running backwards is prohibited.

Using the equipment two at a time is prohibited.

Any distractions in the area around the equipment may cause the user to lose his/her balance.

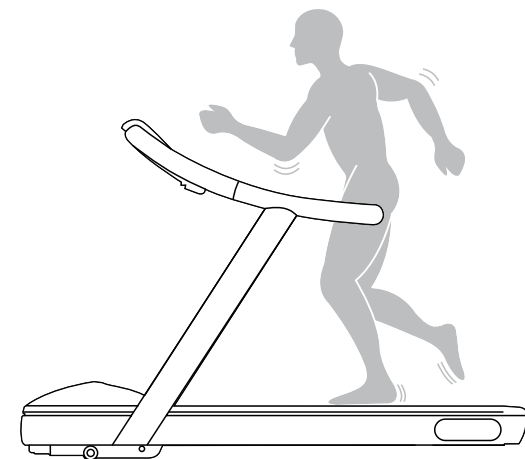
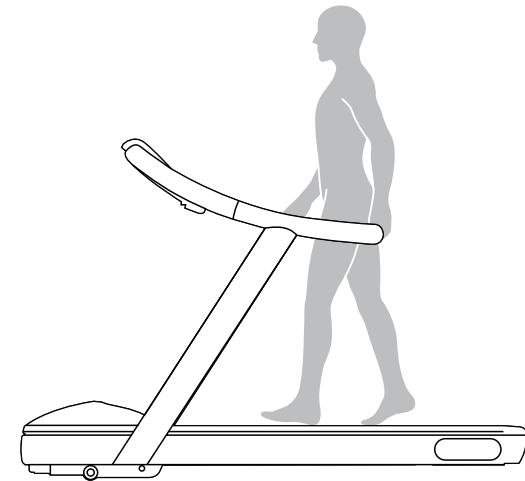

Jog Forma_uk-AC
OSM00750



The Wellness Company